

Single Arm Desktop Monitor Mount

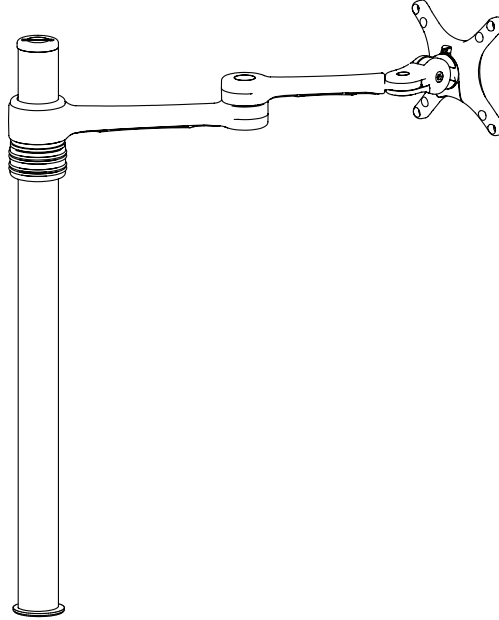

COMPONENT CHECKLIST

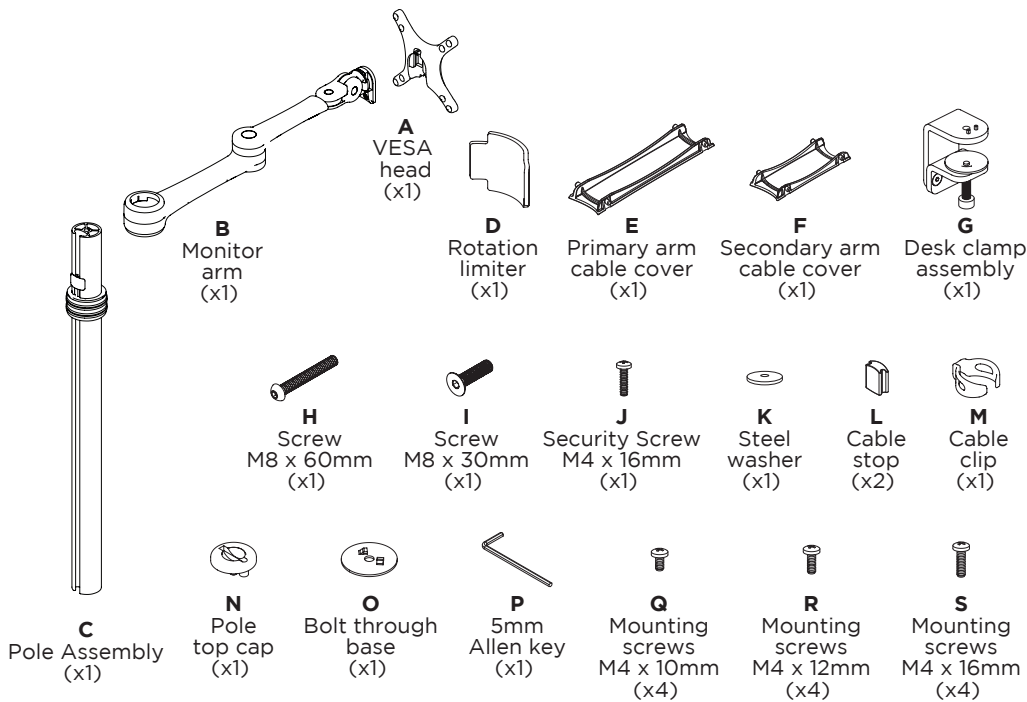

REQUIRED TOOLS

- Phillips Head Screwdriver

WEIGHT RANGE

Flat Monitors

0 - 8kg
(0 - 17.6lbs)

Curved Monitors

0 - 5.5kg
(0 - 12lbs)

IMPORTANT INFORMATION

! Please ensure this product is installed as per these installation instructions.

! This product is compatible with the range of AF Poles and arms.

! The manufacturer accepts no responsibility for incorrect installation.

! Curved monitors, deep devices (such as all-in-one PCs) and offset VESA locations exert additional leverage that can exceed the capacity of the mount even though the monitor weight may be within the stated range. Please contact Atdec if you would like further information.

1. Desk overview

The desk clamp bracket can be repositioned to suit different mounting surface thicknesses.

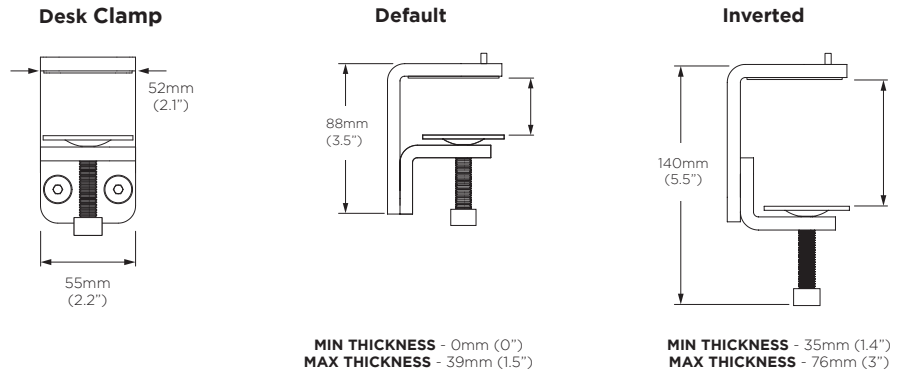

2. How to reconfigure desk clamp

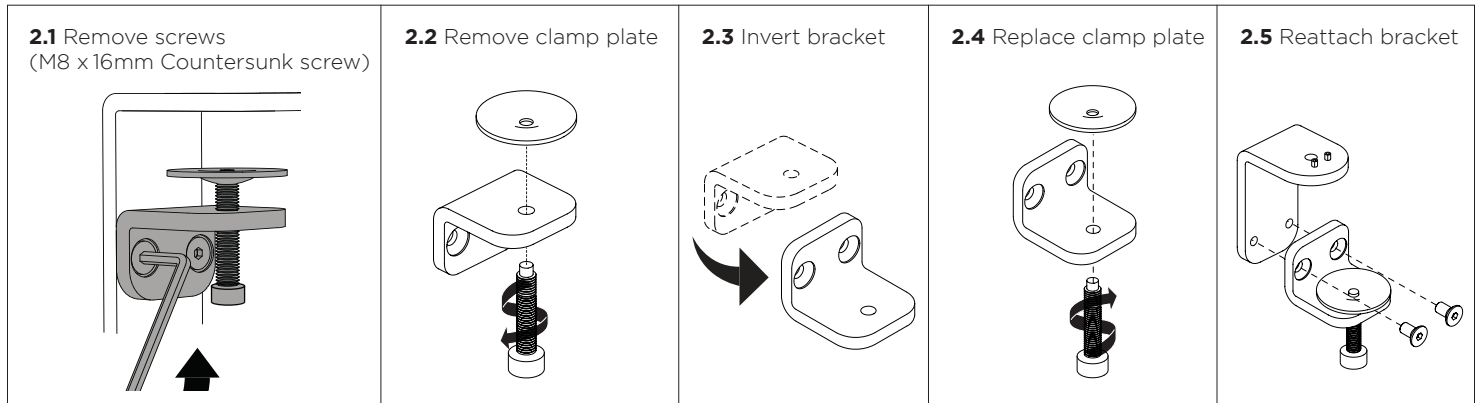

3. Post mount configuration

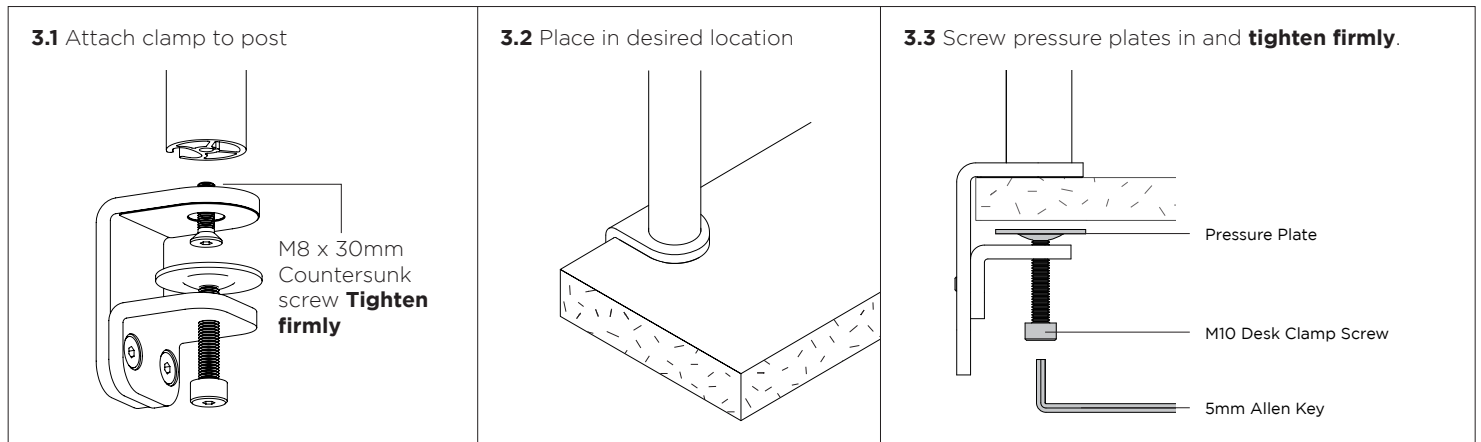

4. Bolt through - Drill Hole

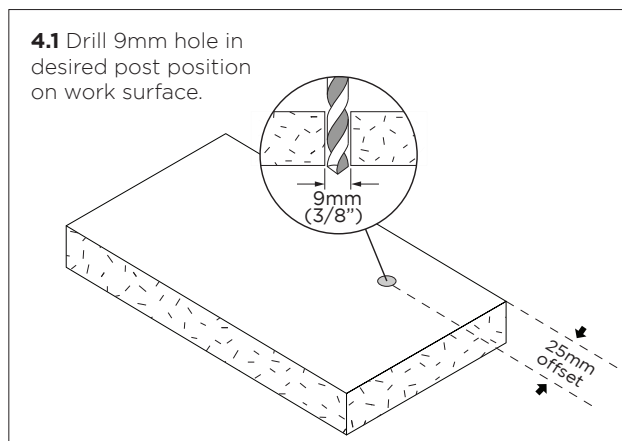

5. Bolt Pole to work surface

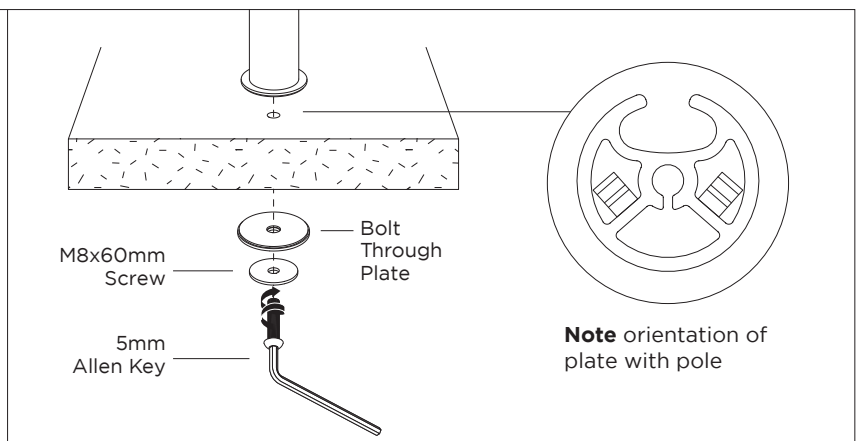

6. Install VESA monitor head

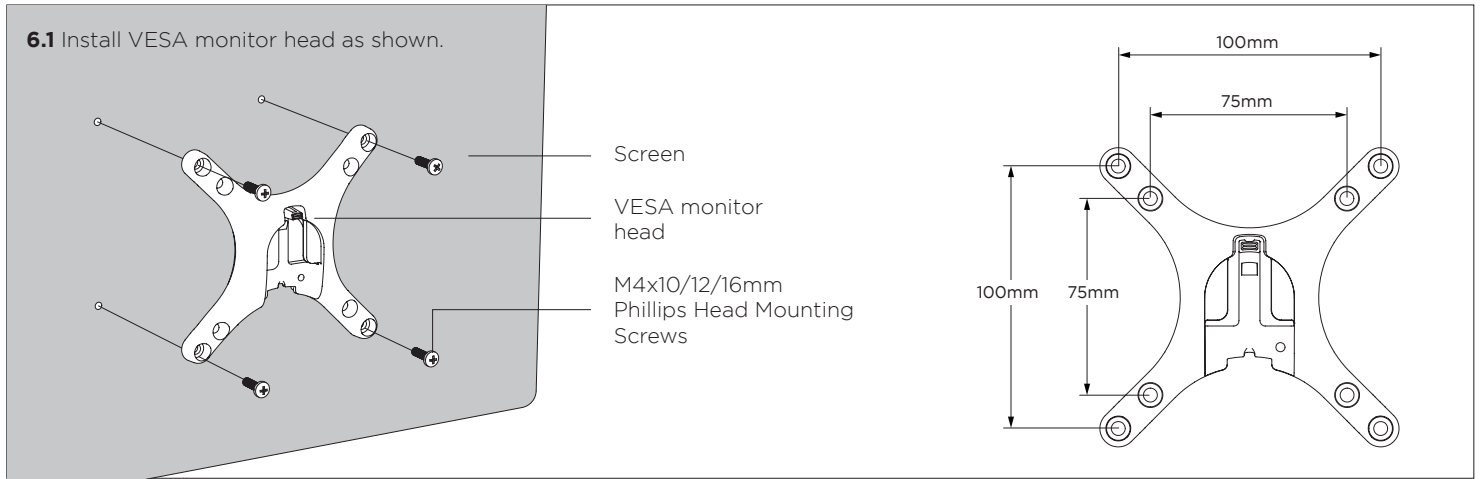

7. Install arm assembly

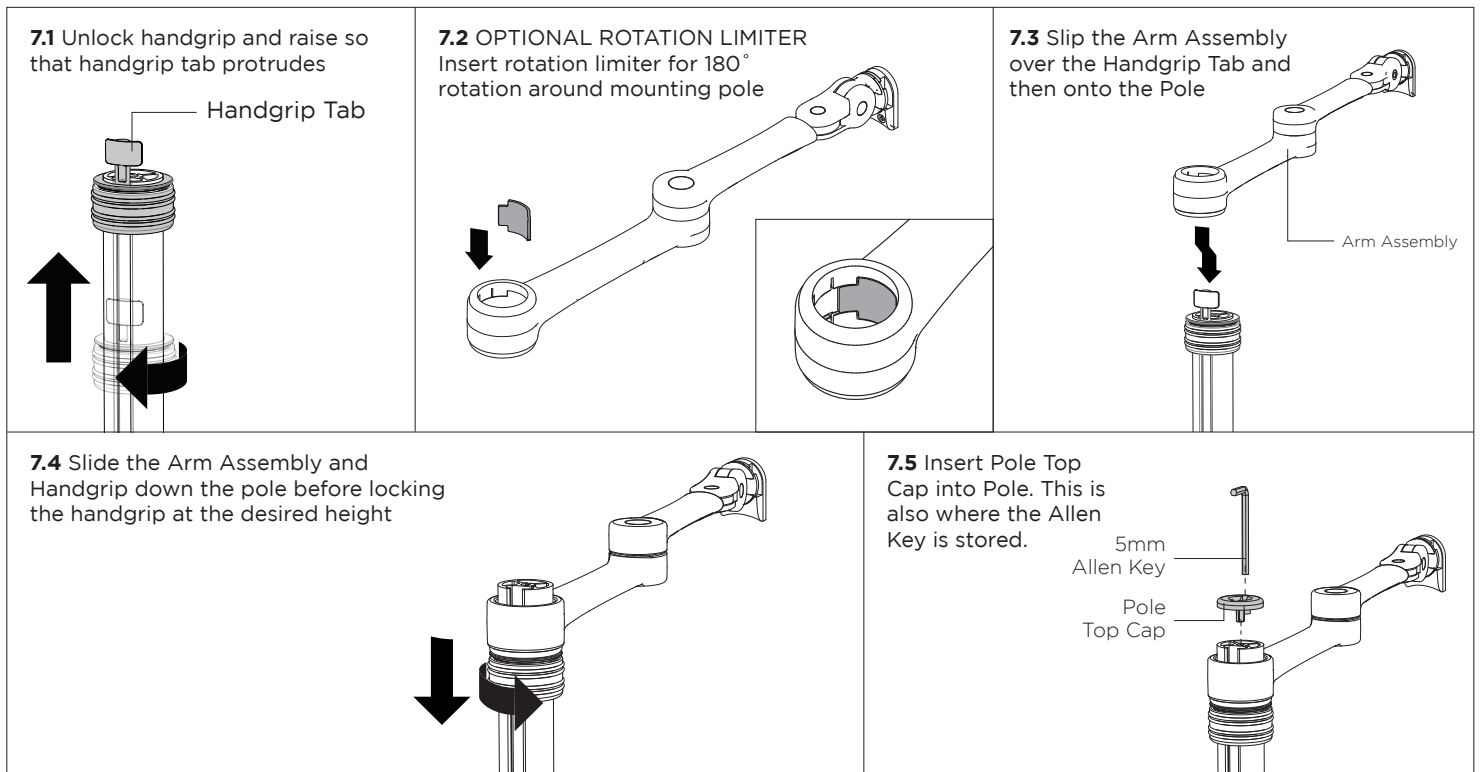

8. Mounting Monitor

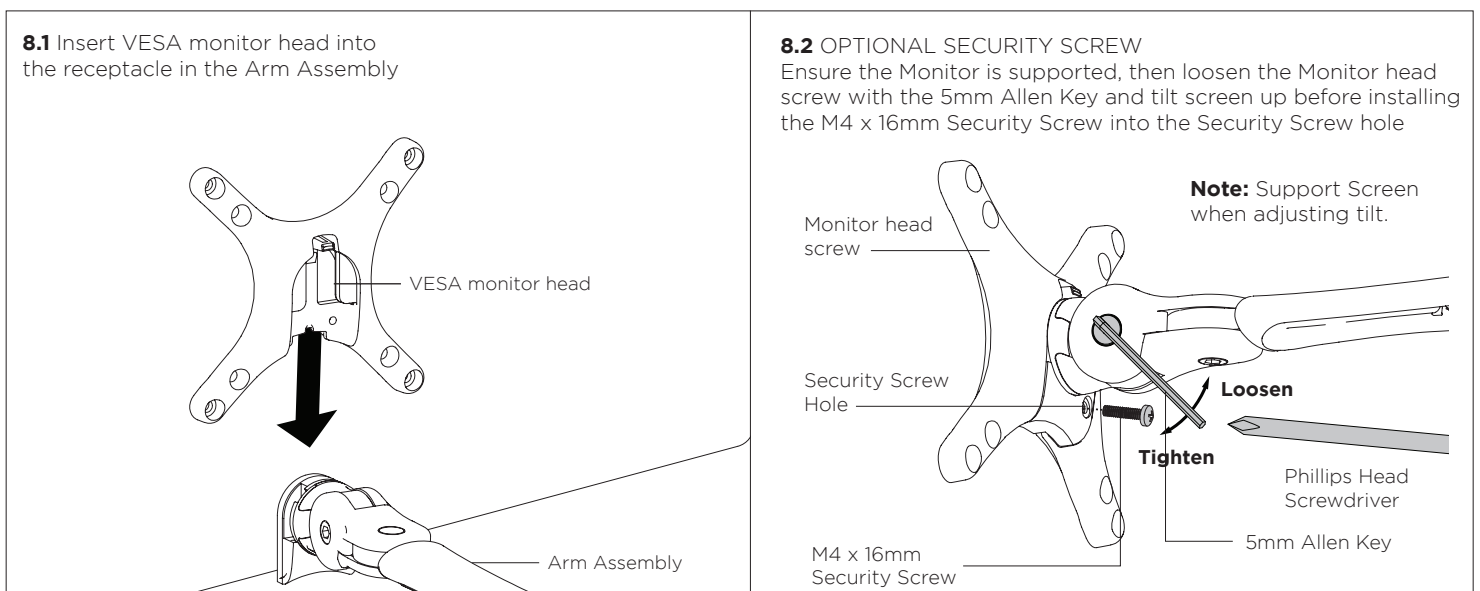

9. Adjusting Height

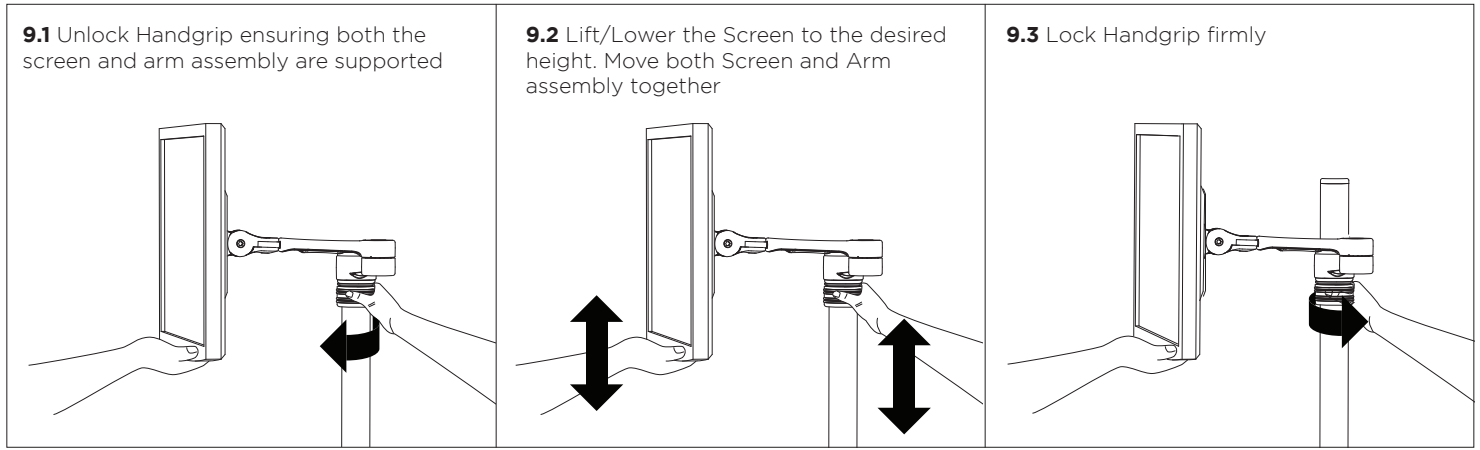

10. Cable Management

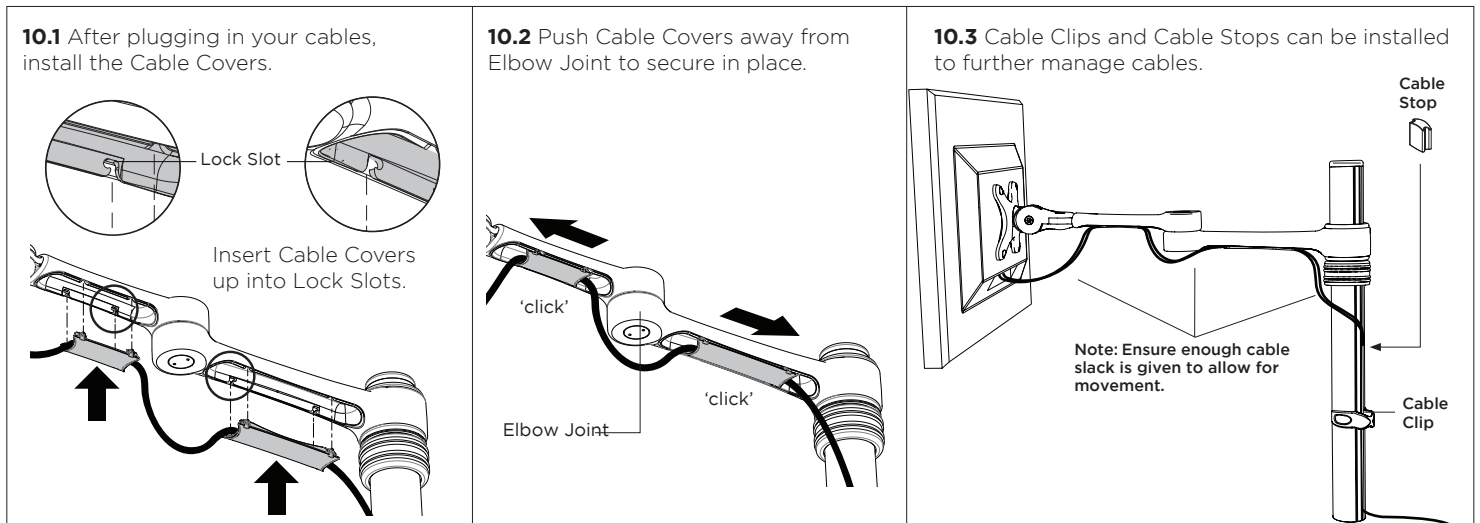

11. Insert Cable Stops

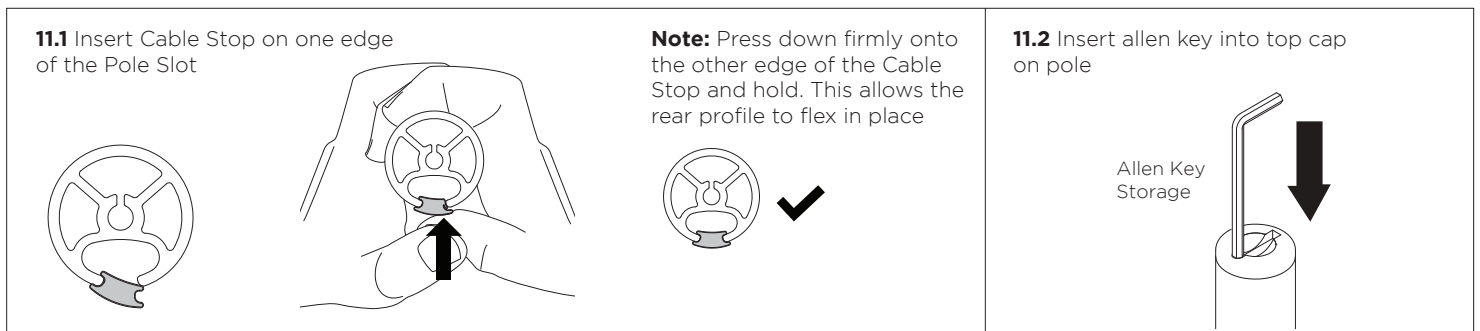

12. Adjusting the Display Bracket

